

# Air conditioner WDH- FGA1075



Dear Customer,

You have chosen a high-quality product. To ensure that you get a lot of enjoyment from this product, here are a few more tips:

**After transport:**

Since the unit uses refrigerant, improper transport can sometimes occur despite careful instructions on the carton. Therefore, we ask you to let it stand upright for at least 4 hours before using it for the first time so that the refrigerant in the unit can settle again.

**In case of any problems:**

We hope that the unit meets your expectations! If, despite the greatest possible care, there should ever be cause for complaint, please contact us briefly, as we are very concerned about your satisfaction and would like to clear up any misunderstanding.

## Important safety instructions:

- Operate the unit only in a straight position and with a straight/level stance (Fig. 1) !
- Make sure that no moisture gets into or onto the unit (Fig. 2) !
- Make sure there is a minimum distance of approx. 40 cm to fixtures and walls (Fig. 3) !
- Watch out for electricity, never walk into or insert objects into the appliance (Fig. 4) !
- The unit is filled with the flammable refrigerant R290, therefore strictly follow the instructions of this manual and read it completely. (Fig. 5)
- Do not carry out any repairs on the unit yourself ! (Fig. 5)
- Do not place any objects on the appliance and make sure that the air intake and the exhaust air are always free!
- Supervise the air conditioner when children or animals are near the unit !
- This air conditioner should only be operated by persons who have the necessary physical and mental capabilities to operate this unit without problems !
- This air conditioner is only approved for indoor use !
- Only qualified personnel or electricians are allowed to open the unit !
- Only use the recommended voltage for operating the unit !
- Make sure that the power cable is unfolded (untied) before connecting it to the socket !
- Please do not use the power cable as a pull cable for the air conditioner !
- Make sure that the plug is cleanly and properly connected to the socket before using the appliance !
- Never reach near the plug or socket with wet hands !
- Make sure that flammable or explosive substances (e.g. gases/oils etc.) are never in the vicinity of the unit !
- If you are not going to use the unit for a long time, switch it off and disconnect the mains plug !

Please switch off the unit immediately and disconnect it from the mains/power supply if anything seems to be wrong ! In this case, please contact a specialist and do not try to repair the unit yourself !!!

**Examples:** Fan does not run during operation, fuse has blown or compressor rattles loudly.

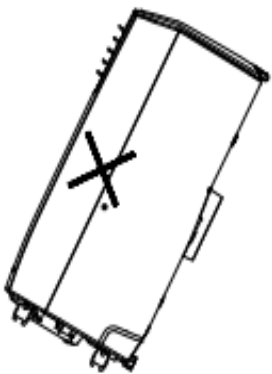

Fig. 1



Fig. 2

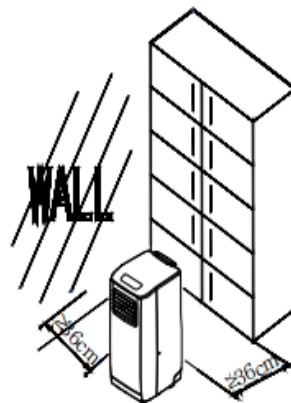

Fig. 3

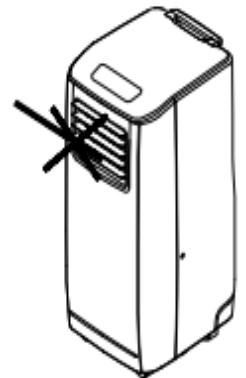
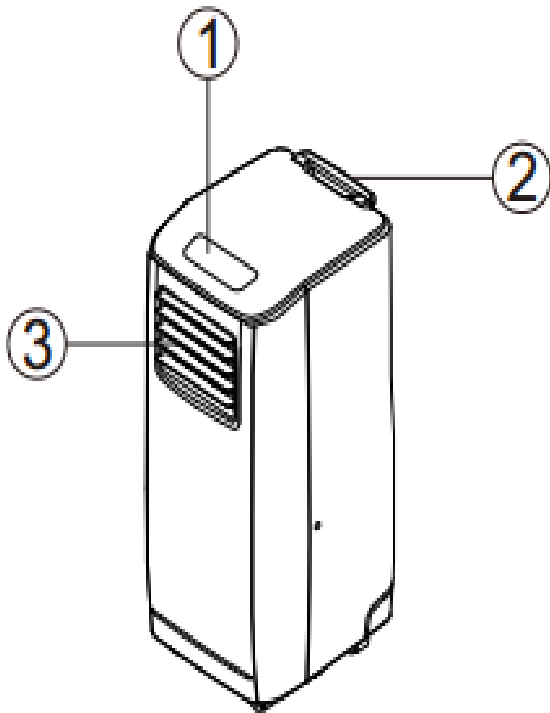

Fig. 4



Fig. 5

## Description of the unit parts:



### Front

1. control panel
2. carrying handle
3. exhaust air (cold)

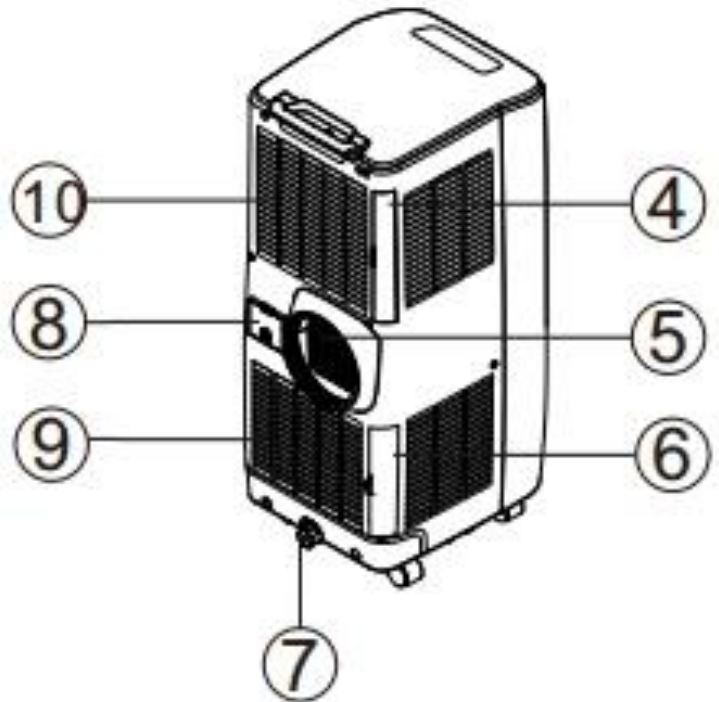

### Back

4. air filter
5. exhaust air duct (warm)
6. air filter
7. condensation drain
8. mains plug compartment
9. air intake
10. air intake

### Accessories:

11. adapter for connecting the warm air hose with the window slit/shutter bar
12. exhaust air hose for warm air
13. active carbon filter
14. sealing strip for window gap (3-part)
15. condensation water drain hose
16. remote control
17. adapter for connecting the warm air hose to the air conditioner

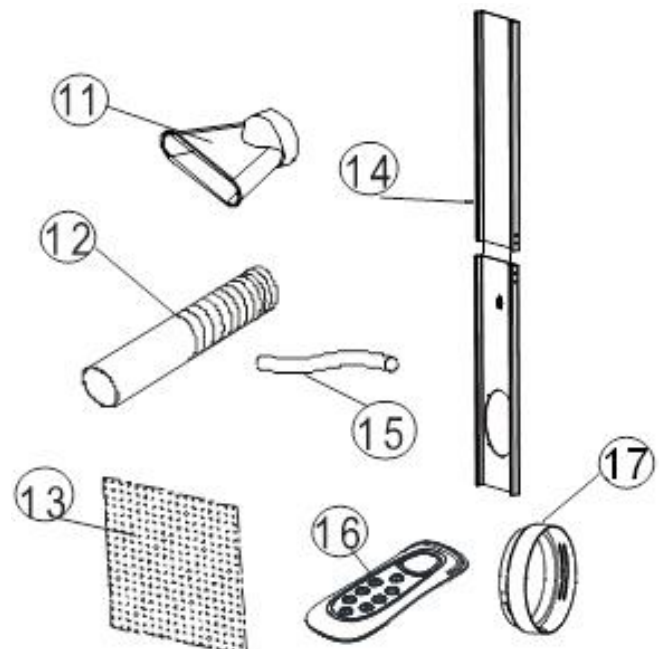

## Operating recommendations:

For good cooling results and for the most effective and economical operation, we give you the following recommendations:

- For this air conditioner we recommend a room size of up to 20 m<sup>2</sup> (50 m<sup>3</sup>) !
- The minimum size of the room in which the unit is to be operated is at least 11m<sup>2</sup> !
- Lock windows and doors.
- Avoid direct sunlight into the room through windows and doors. It is best to close the shutters or curtains during the day.
- Always keep the air filters of the air conditioner clean.
- Once you have reached the desired room temperature, reduce the operating strength of the air conditioner.

## Set-up and connection:

1. connecting the exhaust hose for the warm air

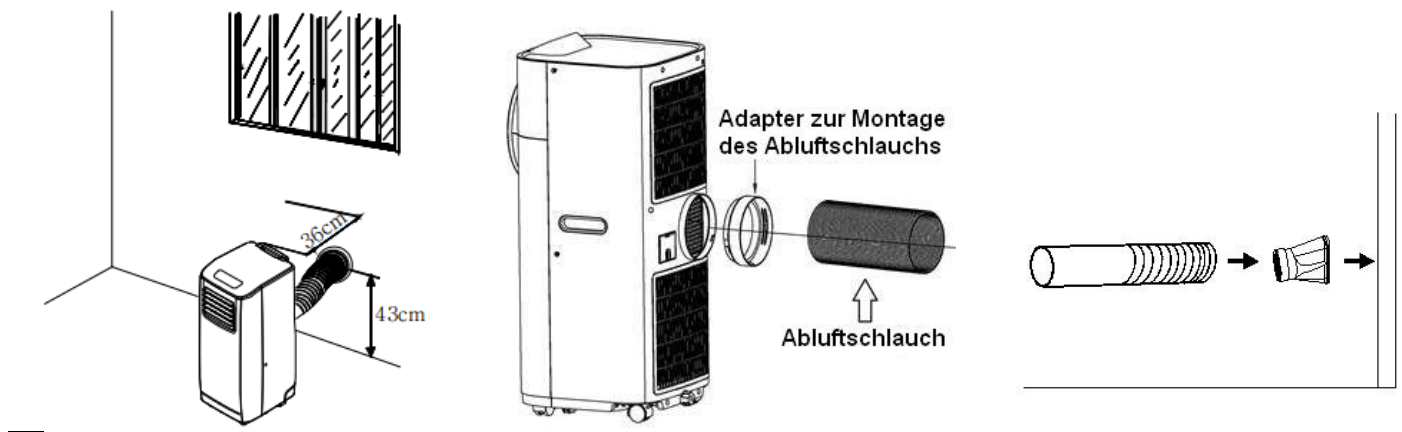

The mobile air conditioner generates warm exhaust air during cooling. This warm exhaust air must be discharged to the outside. You can either direct the warm exhaust air outside through a suitable hole (160 mm diameter) in the wall (similar to a kitchen extractor bonnet) or discharge it through a gap of an open window/door.

Note: Depending on the given conditions, it may be advantageous to use the closure strip provided for this purpose. The closure strip is variably adjustable and can thus ensure that no air from outside gets inside.

- 1.1. Connect the exhaust hose for the warm air to the rear exhaust duct of your air conditioner by first fitting the hose adapter (ring-shaped) to the unit and then screwing on the warm air hose clockwise.
- 1.2. Attach the supplied adapter for the sealing strip to the other end of the exhaust air hose.
- 1.3. If you have installed the closing strip at the window gap/door gap/wall, now insert the adapter into its intended recess. Alternatively, guide the adapter through the window gap/door gap to the outside so that the warm exhaust air can be blown out unhindered.

- 1.4. Finally, check the correct fit/installation of the exhaust air exhaust air hose for discharging the warm air.
- Always use only suitable accessories for connecting and the discharge of the warm air !
  - The exhaust air hose must never be kinked or difficult for the exhaust air to pass through (see illustration opposite) ! This can otherwise lead to overheating of the unit with The following shutdown and/or even a defect in your air-conditioning unit!
  - The exhaust air hose can be extended from 30 cm to a maximum of 150 cm. But for maximum effectiveness and economy, we recommend the shortest possible length !

### Warning:

The length of the exhaust air hose is specially adapted to the specification of the air conditioner. Please do not exchange the exhaust air hose with or try to extend it. This may result in damage to or loss of performance of your unit!

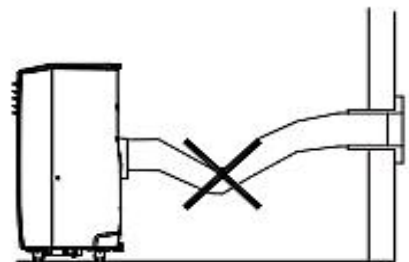
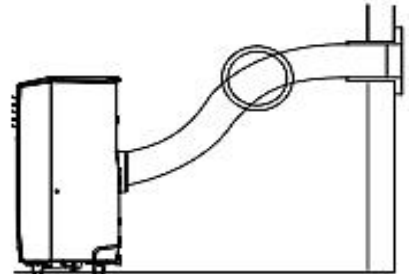
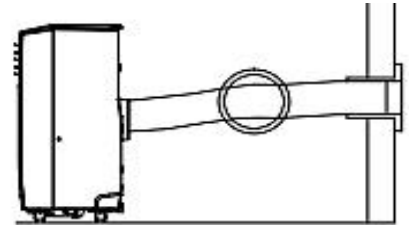
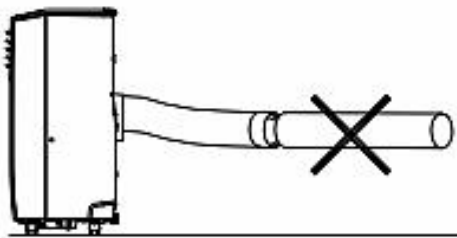

## 2 . The air filter

- 2.1. Take the rear upper filter unit out of the air conditioner.
- 2.2. Detach the filter holder from the filter frame
- 2.3. Take the supplied activated carbon filter out of the plastic bag
- 2.4. Insert the activated carbon filter into the rear upper filter frame
- 2.5. Now put the filter holder on the filter frame
- 2.6. Finally, push the filter unit back into the air conditioner.

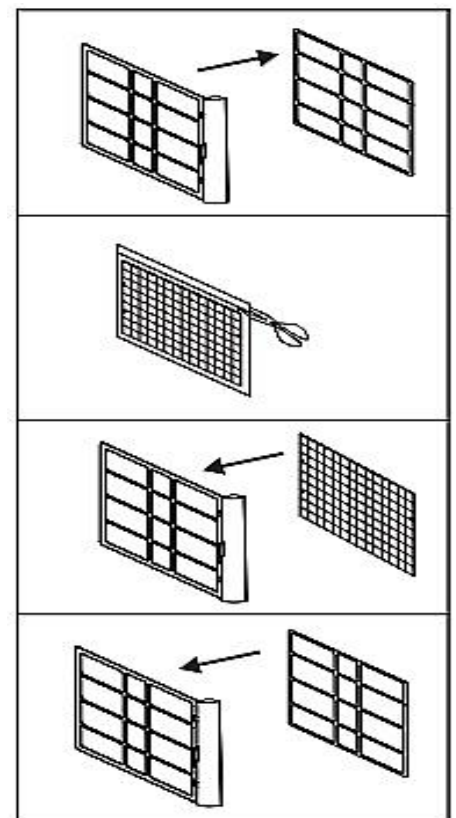
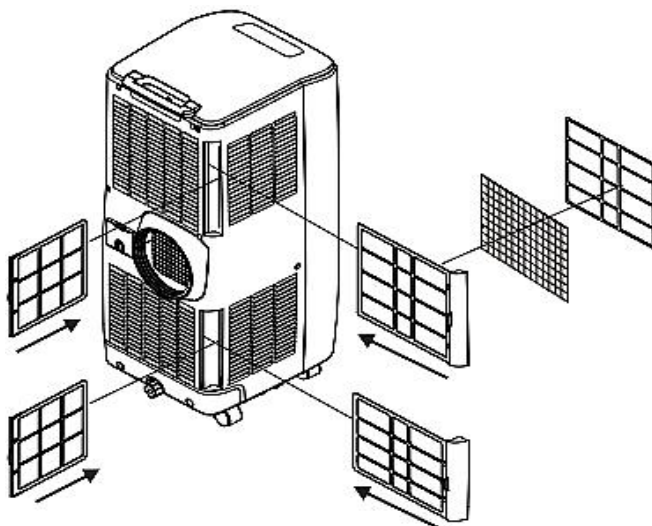



## Functional description of the control panel:

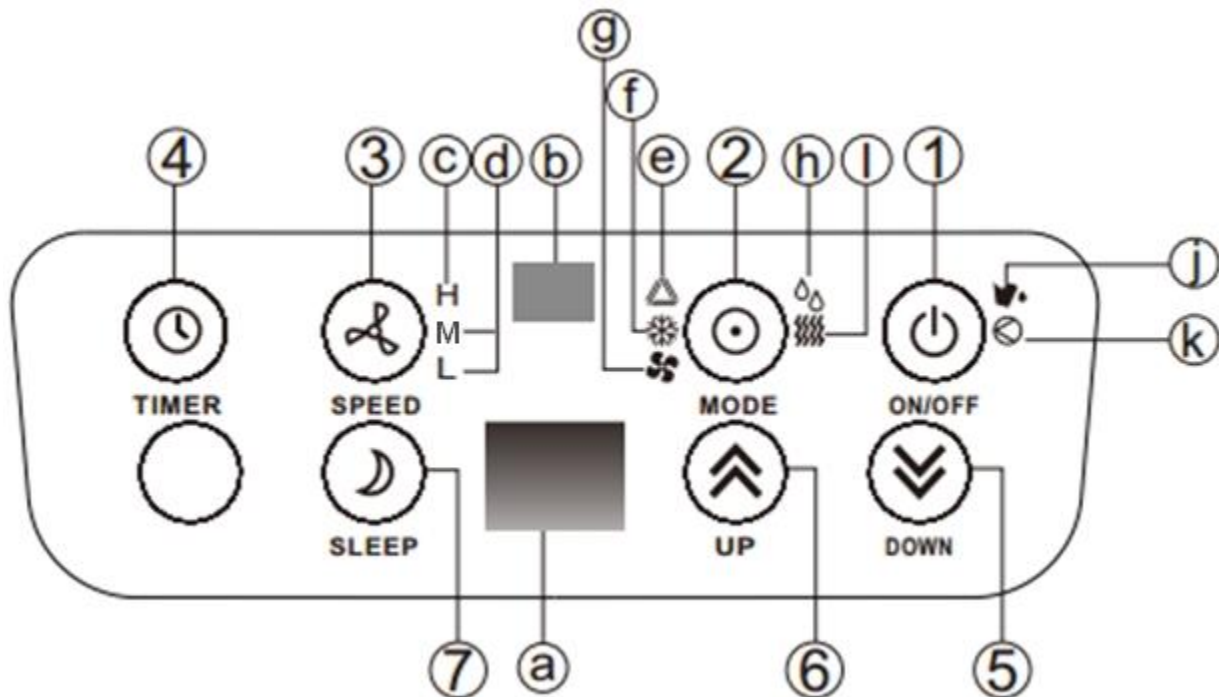

- |  |   |
|--|---|
| <ol style="list-style-type: none"> <li>1. On / Off button a</li> <li>2. Setting the operating mode b</li> <li>3. Setting the operating strength</li> <li>4. TIMER (remaining time/start time 1-24 hrs.)</li> <li>5. DOWN button to lower the room temperature</li> <li>6. UP button to increase the room temperature</li> <li>7. SLEEP = silent night operation f</li> </ol> | <ul style="list-style-type: none"> <li>. Display field (temperature etc.)</li> <li>. Receiver diode for the remote control</li> <li>c. Signal light for high operating strength (H)</li> <li>d. Signal light for average operating strength (M)</li> <li>d. Signal light for low operating strength (L)</li> <li>e. Signal light when automatic mode is activated</li> <li>. Signal light when cooling mode is activated</li> <li>g. Signal light when fan operation is activated</li> <li>h. Signal light during dehumidification operation</li> <li>i. Signal light when heating mode is activated (inactive on this unit type).</li> <li>j. Signal light when the water tank is full</li> <li>k. Signal light for active compressor operation</li> </ul> |
|--|---|





## Instructions for use:

### 1. Commissioning

- 1.1. Insert the mains plug properly into the socket.
- 1.2. Check that the exhaust hose for the warm exhaust air is properly installed (see page 4-5 of the instructions for use).
- 1.3. Make sure that the horizontally mounted outlet louvres are open towards the desired direction.
- 1.4. Press the ON/OFF switch. The air conditioner switches on and the default setting Automatic mode with medium operating strength starts to work. The default target temperature is 24°C. At the same time, the operation/signal lights turn on. (Note: The room temperature display panel can display values from 0°C to 50°C. )

## 2. Selection of the operating mode

Press the MODE button to select the desired operating mode:

- A)  = Automatic mode / Auto mode (see point 5.)
- B)  = Cooling mode
- C)  = Fan operation
- D)  = Dehumidification mode

The operating mode you have just selected is indicated by a small signal light ! (See also the functional description of the control panel)

## 3. Setting the temperature target

Press the "UP button" (to increase the room temperature) or the "DOWN button" (to decrease the room temperature) until you have selected your desired temperature target in the display field.

Note: The temperature target is only displayed while the UP/DOWN key is pressed. After a short wait, the display field shows the current room temperature again. You can set your target temperature between 18°C - 32°C !

## 4. Setting the operating strength

Press the SPEED button (SPEED = air circulation speed setting) to select your desired operating speed:

- A) H = High operating strength
- B) M = Average operating strength
- C) L = Weak operating strength

Note: In automatic mode, the operating strength is set automatically by the unit ! The operating level you have just selected is indicated by a small signal light next to the key ! (See also the functional description of the control panel).

## 5. Using the automatic mode / Auto mode

By selecting automatic mode, the air conditioner attempts to reach or permanently maintain the factory-set temperature target of 24°C and then automatically switches off the compressor after this value is reached.

Note: Using the Auto mode on units without a heating function makes only limited sense, as the Auto mode was originally designed to maintain a constant temperature (automatic heating or cooling as needed).

## 6. Using the timer function

If you want to activate/use the timer function (function for determining the remaining time or function for specifying a start time), press the TIMER key.

### 6.1. Determination of the remaining term:

During operation, press the TIMER button to select the desired remaining time of the air conditioner. (A value between 1 - 24 hours can be selected). After this selected operating time has elapsed, the unit automatically switches off completely.

## 6.2. Determination of a start time:

When the air conditioner is switched off, press the TIMER button to select the desired start time. (A value between 1 - 24 hours can be selected). After this selected time has elapsed, the unit switches on automatically (with the last used settings).

## 7. Activation of night mode (low-noise operation)

Press the SLEEP button and the silent night mode is activated.

The activated night mode automatically increases the target temperature by 1°C in the first hour. In the second hour, the target temperature is automatically increased by another 1 °C. After that, the target temperature is kept at this level.

Furthermore, the night mode always uses the weak operating strength (L).

Pressing the SLEEP key again cancels the silent night mode and reactivates the last selected settings.

Note: After 12 hours of operation in night mode, the air conditioner switches off automatically. In addition, night mode cannot be activated in the following operating modes: Automatic mode, Fan mode or Dehumidification mode.

## 8. Remote control

All functions and settings as described in points 1 - 7 above can also be operated/adjusted with the remote control supplied.

The remote control requires two AAA batteries (not included).



## 9. Error display

The air conditioner detects malfunctions and displays them in the unit's display panel. If the display field shows "E1" or "E2", please contact your dealer.

## 10. Other operating instructions

- 10.1. To ensure a long service life of the compressor, please do not switch the unit off and on again within 3 minutes (switching the unit off and then on again shortly afterwards will damage the compressor).
- 10.2. The cooling circuit (compressor) switches off as soon as the ambient air is below the target temperature. However, the air circulation continues. If the ambient air rises above the target temperature, the cooling circuit (compressor) also switches on again automatically.

## 11. Operating instructions regarding refrigerant R290

- Read these instructions carefully !
- This air conditioner operates with the refrigerant R290, which is highly flammable and explosive. Therefore, please take special care that the copper lines are not damaged at any time!
- The appliance should not be placed in a room where other appliances are operated at the same time which have an electric heater or an open flame.
- Please note that the refrigerant is odourless and therefore a leak cannot be detected immediately by an emerging odour !
- Make sure that the outlet of the exhaust air is always given and not obstructed by other objects !
- Only appropriately trained specialists are permitted to carry out repairs to the cooling lines and the compressor! Always contact a specialist in case of a problem !



## Condensation:

Some condensation forms in the unit during the cooling process. This side effect is caused by the extraction of moisture from the ambient air during the cooling process. This condensation water is collected and fed into the integrated condensation tank. If the integrated condensation tank is full, the compressor and the motor of the air conditioner switch off. In addition, this condition is signalled by the "Water Full" signal light on the control panel and by a beep !

To drain the condensation water tank and thereby reactivate the air conditioner, please follow the steps below:

1. Switch off the air conditioner and avoid moving the unit when the condensation tank is full.
2. Position a drip tray below the drain hole (1) for the condensation water.
3. Unscrew the cap (3) and then remove the rubber plug (2) by pulling it out horizontally. Now the condensation water can drain out of the tank.
4. If your drip tray is full but there is still water in the condensation tank, simply put the rubber plug back on the drain hole and then empty the drip tray.
5. Repeat this procedure until the condensation tank is completely empty.
6. Now put the rubber plug back on the drain hole and finally screw the cap back on properly.
7. Finally, you can switch the mobile air conditioner on again and the "Water Full" signal light on the control panel should now go out.

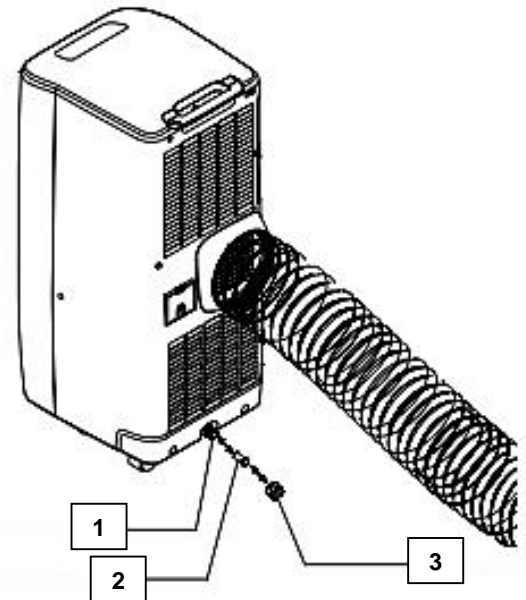

If you want to operate the air conditioner without the condensation tank, please take the following steps:

1. Unscrew the cap and then remove the rubber stopper by pulling it out horizontally. Keep both cap parts in a safe place for later use.
2. Connect the plastic hose supplied to the condensation drain hole and lead off the other end so that there is a slope and the condensation can drain off easily/unhindered (see fig. below).
3. The drain hose can be extended or also replaced. In this case, please use a suitable hose. A 3/4 inch hose is best suited/fitting.

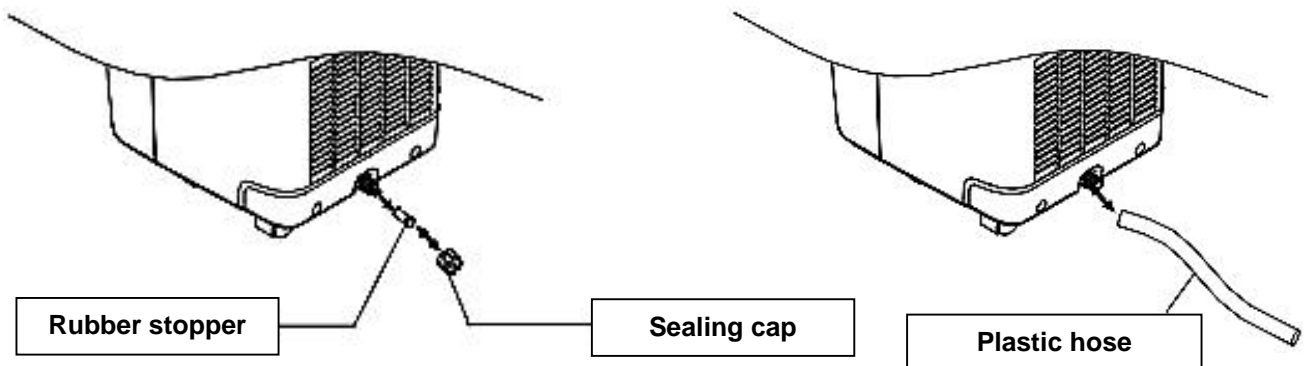

## **Cleaning:**

Always disconnect the mains plug before cleaning your air conditioner !  
To keep the effectiveness and service life of your air conditioner high, please clean this unit regularly !

### Cleaning the housing:

Use a soft and damp cloth to clean the housing of the air conditioner. Please do not use aggressive cleaning agents, they may damage your unit !

### Cleaning the filters (does not apply to the activated carbon filter net):

Use a Hoover to clean the filters or tap them out gently.  
Alternatively, you can rinse the filters under running water. Please make sure that the water is no hotter than 40°C.  
Allow the filters to dry completely before putting them back into the appliance !  
Note: Please never operate the air conditioner without a filter !

## **Stow the air conditioner:**

- Empty any condensation water from the condensation tank.
- Let the unit run in ventilation-only mode for a few hours to allow it to dry completely from the inside.
- Clean the filters.
- Pull out the mains plug and stow it in the mains plug compartment provided (see adjacent illustration).
- Use the original carton to store the air conditioner.

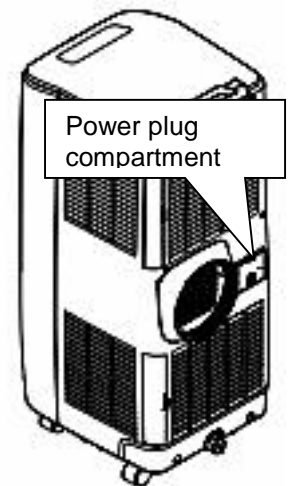

## **Troubleshooting:**

### The unit does not switch on:

- Check the mains plug and try a different socket.
- Check if the house fuse has popped out.
- Check whether the condensation tank is full ("Water Full" signal light is on). If the condensation tank is full, empty it (see page 9).
- Check whether the room temperature is perhaps already below the selected target temperature.
- It could be that the overheating protection of the unit is switched on. In this case, try again after a short while and in cooler conditions.

### The unit does not cool enough:

- Make sure that the unit is not in direct sunlight.
- Make sure that no windows or doors are open.
- Is it possible that there are too many heat sources in the room? Please consider that every person, every window exposed to sunlight and every electrical appliance produces heat and therefore the cooling capacity of the air conditioner may no longer be effective enough.
- Make sure that the filter is not dirty and is sufficiently permeable to air.
- Make sure that the air intake, the exhaust air and the exhaust air duct for the warm air are not blocked and have sufficient free space.
- Check whether the room temperature is perhaps already below the selected target temperature.

The unit seems too loud to me:

- Check that the unit has a firm stand with all four castors and is not uneven. Quieter operation is achieved if the air conditioner is placed on a carpet or a piece of floor mat. Furthermore, a short exhaust hose for the warm air in the room is advantageous.

**In the event of a defect, do not attempt to repair the air conditioner yourself!**

## Technical data:

<b>Model designation:</b>	WDH-FGA1075
<b>Energy efficiency rating (EER):</b>	A
<b>Energy consumption per hour according to EER:</b>	1.115 kW/h
<b>Cooling capacity:</b>	10,000 BTU/h (2,930 watts)
<b>Energy efficiency ratio (EER):</b>	2,6
<b>Unit type:</b>	Cooling only
<b>Cooling type:</b>	Air cooling
<b>Noise emission:</b>	65 dB(A)
<b>Voltage:</b>	220-240V ~ 50Hz
<b>Max. Power consumption:</b>	1,130 W (5.0 A)
<b>Power consumption in operating mode "Temperature controller off" (PTO):</b>	155 W
<b>Power consumption in standby mode (PSB):</b>	0,4 W
<b>Electricity consumption (QSD):</b>	1.12 kWh/a
<b>Air circulation:</b>	350 m <sup>3</sup> /h
<b>Dehumidification capacity:</b>	1.0 litre/h
<b>Range of use:</b>	18°C - 32°C
<b>Compressor:</b>	Rotary compressor
<b>Refrigerant:</b>	R290 (230 g)
<b>Dimension (H/W/D):</b>	770 x 317 x 402 mm
<b>Dimension hot air duct:</b>	Ø 150 x 1500 mm
<b>Intake pressure:</b>	0.85 Mpa
<b>Discharge pressure:</b>	2.2 Mpa
<b>Weight:</b>	25,5 kg

The above data have been determined in accordance with EU standard: EN 14511, as well as EU safety and test regulations: EN 60335-2-40.

COOLING - dry temperature = 35°C; wet temperature = 24°C

Fuse: F2AL250V or T2AL250V

## Other:

### Warranty statement:

Notwithstanding the statutory warranty claims, the manufacturer grants a warranty in accordance with the laws of your country, but at least 1 year (in Germany 2 years for private individuals). The warranty begins on the date of sale of the appliance to the end user.

The guarantee only covers defects that are due to material or manufacturing faults.

Warranty repairs may only be carried out by an authorised customer service. To make a warranty claim, please enclose the original sales receipt (with date of sale).

Excluded from the guarantee are:

- Normal wear
- Improper applications, such as overloading the appliance or non-approved accessories.
- Damage due to external influences, use of force or foreign objects
- Damage caused by non-observance of the operating instructions, e.g. connection to an incorrect mains voltage or non-observance of the assembly instructions.
- Completely or partially dismantled units

### Conformity:

The air conditioner has been tested and itself and/or parts thereof have been manufactured under the following (safety) standards:

**"GS" tested by Intertek, and of course with CE (EMC + LVD) conformity.**

Tested safety according to: EN 60335-2-40:2003+A11:04+A12:05+A1:06+A2:09+A13:12  
EN 60335-1:2012+A11:14+A13:17  
EN 62233:2008  
AfPS GS 2014:01 PAK

CE conformity tested according to: EN 55014-1:2017  
EN 55014-2:2015  
EN 61000-3-2:2014  
EN 61000-3-3:2013

### Correct disposal of this product:



Within the EU, this symbol indicates that this product should not be disposed of with household waste. Waste equipment contains valuable recyclable materials that should be recycled and not harm the environment or human health through uncontrolled waste disposal. Therefore, please dispose of old appliances via suitable collection systems or send the appliance for disposal to the place where you purchased it. They will then recycle the appliance.

I wish you much pleasure with this appliance.

*Your Aktobis AG*

***Keep these instructions for use in a safe place !***